

OPC DAY
FINLAND 2021
16.11.2021

OPC UA Information Model for Cranes

Henri Gört

KONECRANES®



FINNISH SOCIETY OF AUTOMATION
SUOMEN AUTOMAATIOSEURA RY

SPONSORS:

BECKHOFF

NAPCON

Nortal

OPC
FOUNDATION

PROSYS OPC

Life Is On

Schneider
Electric

Semantum

Valmet
FORWARD

Wapice

What are we modelling?

- OPC UA companion specification for cranes
 - OPC UA Companion Specification for Cranes and Hoists – Part 1:
Vertical integration and communication of limitations from external systems
- Konecranes has been using OPC UA internally for almost 10 years
 - We have had good experiences with using OPC UA. Therefore, it was natural to choose OPC UA as the technology to define the standard information model
 - A partner organization had suggested to define a standard nodeset already several years ago
 - Now, the target is to publish a release candidate of the Companion Specification early next year

Why are we modelling it?

- To make it **faster, easier** and **more efficient** to integrate the crane as part of an **advanced material flow** solution and **Industry 4.0** machine-to-machine communication
- We are working towards that goal together (Joint Working Group) with:
 - Members from **VDMA**
 - **FEM & OPC Foundation** members
 - **Machinaide** Project
- Chairman: Eberhard Becker, Demag Cranes & Components

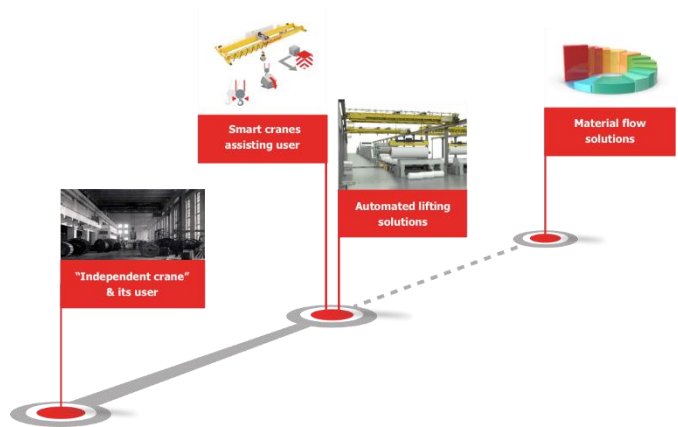

How are we modelling it?

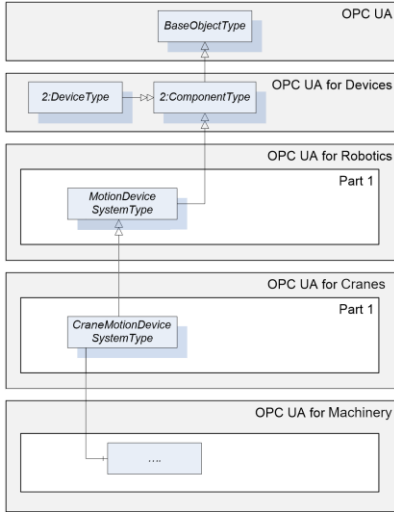

- The crane OPC UA server will be **compatible with Robotics (OPC 40010-1) aware clients on day one**
- Subtyping the Crane from the **Motion Device System** type of Robotics
 - Crane domain extensions on top of the model, but nothing is removed
- Asset management information will utilize the **Machinery Companion Specification**

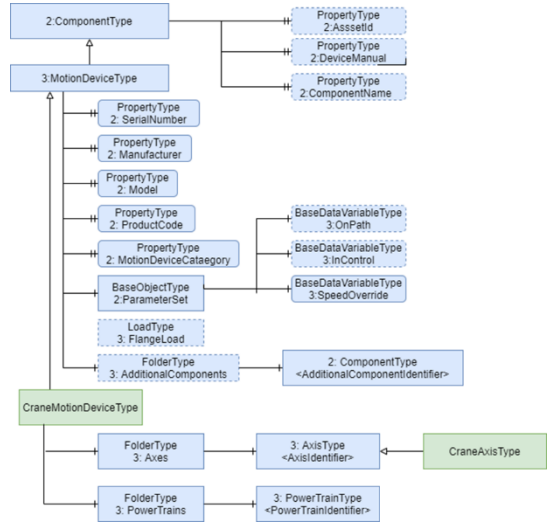
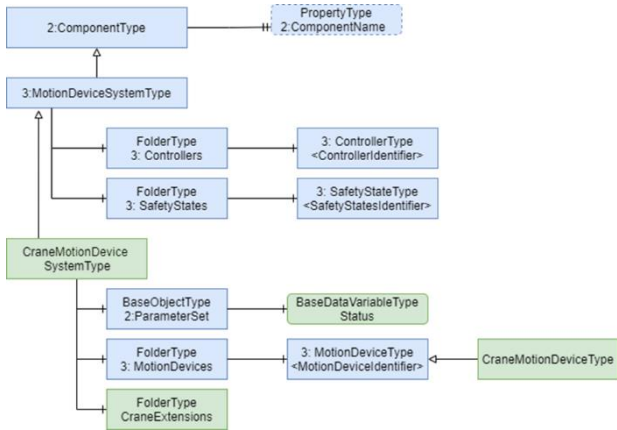

**OPC UA Robotics Companion Specification
OPC 40010-1 (early draft, June 2018)**

**OPC UA Cranes and Hoists Companion
Specification**

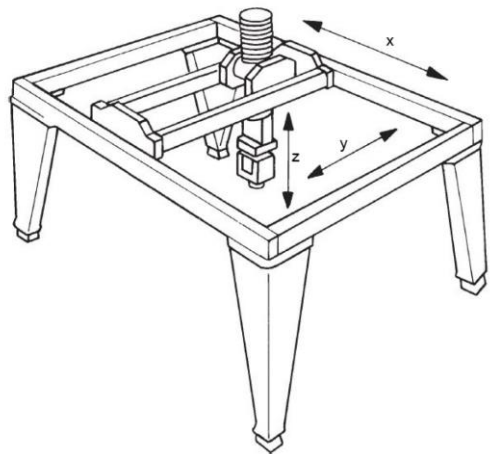
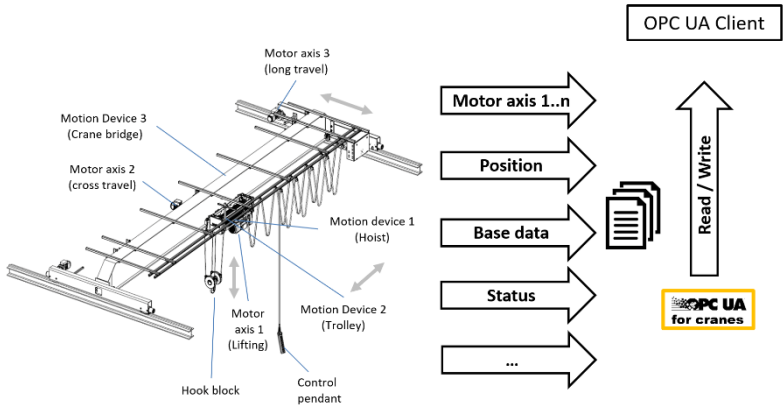
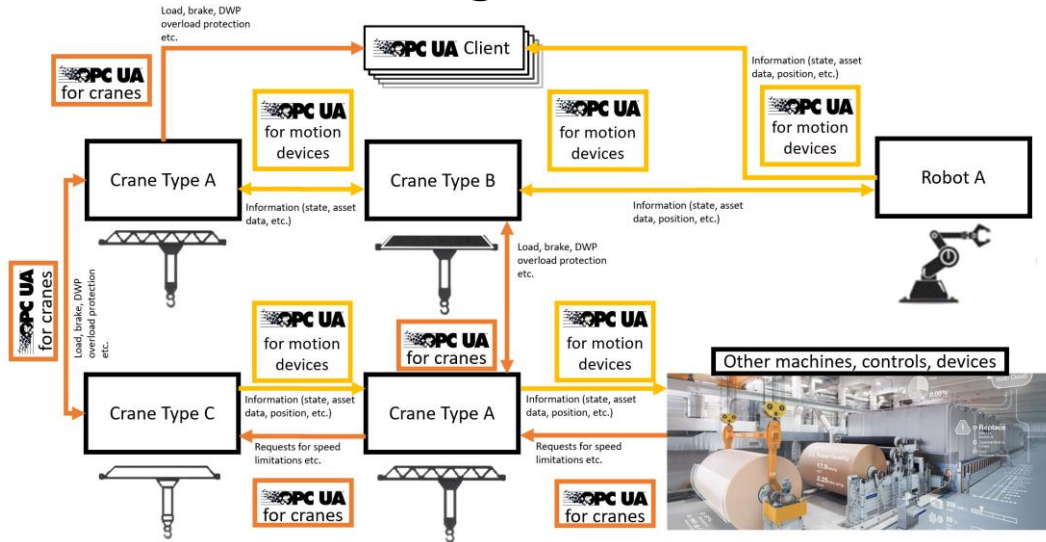

Figure 32 – Portal manipulator



Target state



THANK YOU!

QUESTIONS?